

106
C.E. & D. M.T. Workshops,
R.N.Z. SQUADRON BIRMINGHAM M.C.

LUCAS

TECHNICAL SERVICE

OVERSEAS TECHNICAL CORRESPONDENCE COURSE

Section 6 VEHICLE WIRING CIRCUITS



JOSEPH LUCAS (SALES & SERVICE) LTD · BIRMINGHAM 18



INTRODUCTION

The electrical circuit of the modern automobile can appear most complex to the uninitiated. Careful study however, of the wiring diagrams produced by the Lucas Organisation and the Vehicle Manufacturers will allow the student to study the various circuits both individually and as a whole. The study of each circuit separately before tackling the complete job, is perhaps the best method for the student to adopt, as with few exceptions the electrical system of a motor vehicle can be considered as a series of simple circuits, as for example the Lighting, Charging and Ignition circuits. Having grasped the fundamentals of these circuits it is then possible to consider as a whole the complete Wiring Harness or Wiring Loom.

Motor vehicle wiring has been, and continues to be, subject to many changes, mainly to facilitate speed and convenience on the vehicle assembly lines. With the introduction of snap connectors and separate junction boxes, cable assemblies can now be made up as subsidiaries to the main loom. This considerably assists the manufacturer, whose vehicle in these days of mass production, is often produced at separate branch works in the form of units, i.e. engine, chassis and body, before final assembly. It will be readily seen therefore, that these harness sub-assemblies play an important part both in the initial layout and later in service where rewiring of a damaged section becomes necessary.

Let us now consider the means of identification of this multiplicity of cables. As we have stated, the electrical system is a series of simple circuits, each consisting of the component, its switch and three wires, feed, switch wire and return. The Lucas colour scheme of identification for British cars is based upon this principle. Feed wires carry braiding of a main colour only, switch wires have a main colour of feed with a coloured tracer woven spirally into the braiding and return or earthing leads are black.

These then are the basic principles which will be enlarged upon in the following pages of this section of the course.

For the administrator and store keeper the sections dealing with cable sizes, their current carrying capacity, protective sleeving, rubber grommets will be found invaluable as a general guide when considering the materials to stock, particularly where the rewiring of vehicles is an essential part of the service offered.

In compiling this section on wiring circuits, as installed on modern British cars, we have reduced the technicalities of the subject to a level that should be easily understood by all students.

CONTENTS

PART 1.

Wiring Principles — Simple Wiring Circuit — Earth Return System.

Negative Earth System — Positive Earth System
Connecting Up and Terminal markings.
Methods of wiring.
Cable looms — Junction boxes.
Types of cable in use.
Starter cables — Ignition cables.
Current carrying capacity.

PART 2.

Individual Wiring Circuits — Circuit Identification.

Typical wiring circuit.
Wiring diagrams.
Starter circuit — Manual switch — Relay switch.
Ignition circuit — Charging circuit.
Ignition warning lamp.
Rear lighting — Head lighting — Panel lighting.
Driving lamps — Fog and Reverse lamps.
Auxiliaries — Trafficators — Screenwipers.
Fuel gauge and petrol tank unit.

PART 3.

Rewiring in Service.

Cable stocks — Sizes — Colours.
Protective sleeving.
Snap connectors — Junction boxes.
Partial rewiring — Complete rewiring.
Methods of rewiring.

QUESTION AND ANSWER PAPERS

STUDENTS QUERY PAPER

AIR MAIL REPLY ENVELOPE

COPYRIGHT

*All rights reserved. No part of this
publication may be reproduced
without permission.*

JOSEPH LUCAS (SALES & SERVICE) LTD., BIRMINGHAM, ENGLAND.

SIMPLE ELECTRICAL CIRCUIT

The typical electrical circuit as we know it comprises any component, such as a lamp for example, connected to a supply — which may be a battery — by two wires or cables; a *feed wire* and a *return*. Any electrical installation employing this arrangement is known as an *insulated return system*, and for some time the electrical equipment on vehicles followed this principle.

EARTH SYSTEM

An alternative arrangement suitable for many applications, uses an insulated cable as a feed wire to the component, the return being obtained via *earth*, which on a vehicle is of course the steel chassis.

Such an arrangement reduces both the amount of cable necessary and the complexity of the wiring circuits.

This single pole or earth return system soon became standard practice for vehicle work in general. But

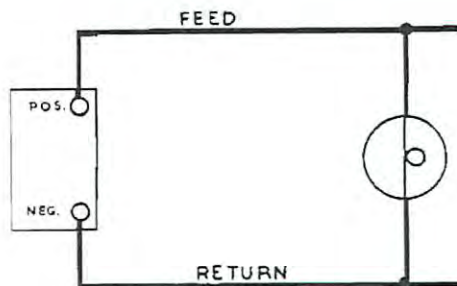

INSULATED RETURN SYSTEM

for many of the larger vehicles such as passenger-carrying and certain heavy commercials, which include petrol carrying vehicles, the *insulated return system* is still used.

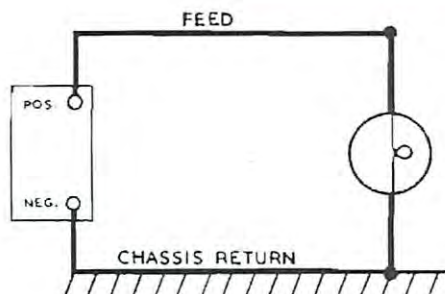

NEGATIVE EARTH SYSTEM

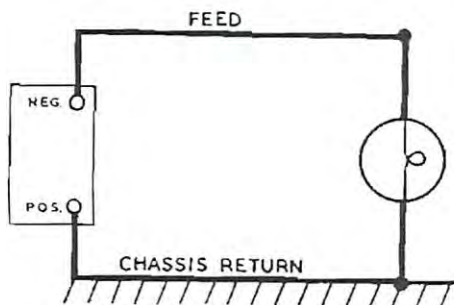

POSITIVE EARTH SYSTEM

NEGATIVE EARTH SYSTEM

With the *earth return system* the orthodox arrangement was to *earth the negative pole* of the supply, and this became known as the single pole negative earth system, which was used for vehicle work for several years — on British vehicles up to about 1936.

POSITIVE EARTH SYSTEM

It was then found that certain specific advantages were obtained by earthing the positive pole of the battery instead of the negative. Thus we had the introduction of the positive earth system, which is almost universally used to-day, except for those specialised vehicles previously mentioned.

One of the main advantages gained by earthing the positive side of the supply is that the polarity of the spark plug central electrode is made negative, which results in improved spark plug performance and longer service life of the spark plugs and the H.T. cables.

At the battery itself the formation of electrolytic sulphation at the positive lug is reduced, and also the marked tendency to electrical leakage from the cells to earth, the result of the presence of acidulated moisture. The corrosion effects at switch contacts, cable connectors, soldered joints, etc. are also reduced, especially under conditions of excessive humidity.

CONNECTING UP AND TERMINAL MARKINGS

A point to be remembered is that this reversal of polarity makes no difference whatsoever to the working of the system or testing for faults, but it has to be borne in mind when fitting the batteries and connecting up cables. Terminals are all properly marked without reference to the polarity, as shown in our picture, i.e. the dynamo and field terminals D and F. (The D terminal being the larger of the two).

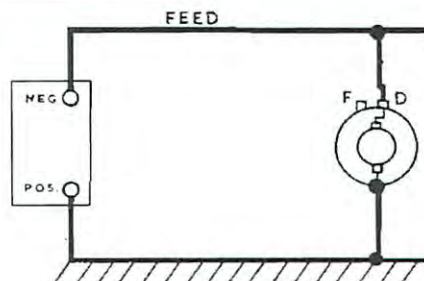

POSITIVE EARTH RETURN

METHODS OF 'WIRING

Now we come to the cables and the method of wiring which is generally by means of a harness. We shall confine ourselves to British vehicles, although most others follow the same general pattern. Our picture shows a wiring loom in course of manufacture.

Multi-coloured cables are employed as a means of facilitating assembly both at the electrical manufacturer's works, and also on the vehicle makers' assembly lines.

Next, the cables are grouped together and braided into looms with individual conductors emerging where required, thus forming main, branch and trunk cables.

The development of this arrangement not only facilitates assembly but also provides considerable protection against chafing on metal edges and subsequent wiring faults in service.

Additionally, sub-assemblies such as the complete car body, or say a steering column may be fully assembled and wired before being positioned on the vehicle. To facilitate the fitting-up, various junction boxes and snap connectors are now widely used.

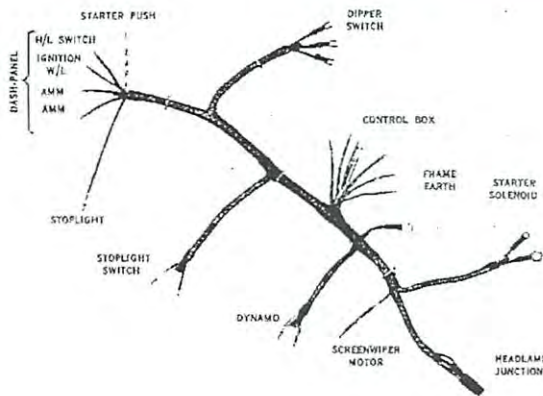

CABLE LOOM

On some vehicles one complete wiring loom may be used; on others as many as four separate looms — one main and two or three subsidiaries are needed and these are finally connected up to the main loom by means of snap connectors or junction boxes. Altogether there is a vast variety of wiring looms made up for different makes and models.

So, unless the vehicle is specially laid out, the stocking and general use of wiring looms is not practicable. For this reason the renewal of damaged wiring is more easily and economically handled in service by putting in single cables and employing either junction boxes or snap connectors to rejoin to the undamaged parts of the existing loom.

JUNCTION BOXES AND CABLE CONNECTIONS

For general purposes, a range of junction boxes and cable connectors is freely available.

The snap or spring connectors shown, greatly facilitate re-wiring and general service work. They are made in numerous combinations.

These spring connectors must be borne in mind when fault finding.



TYPES OF CABLE IN USE

Now before going into circuits and colour schemes, let us examine the types of cables which should be available before embarking on any vehicle wiring repair work.

They fall into three groups :

1. Starter cables, of which there are three sizes.

STARTER CABLES

1. The most generally used pattern is a fairly light type of jute covered cable as shown. This comprises 37 strands of No. 20 SWG tinned copper wire.

It is suitable for most light vehicle work where the starter motor current does not exceed 400 amperes.

2. Used in conjunction with this is a similar size *earth braid* which should always be fitted between engine and chassis as a bonding strip when rubber engine mountings are used.

This standard braid is also suitable for use as the *earth lead* from the *positive* terminal of the battery to the *earth* connection on the scuttle or chassis.

3. The two heavier starter cables are of similar construction to the light one, i.e. jute covered, but have 61 strands of No. 20 or 18 SWG, and are used for starter currents up to 700 amps.

Where this size cable is used for the starter supply, further lengths should be made up as a bonding strip and also as the battery earthing lead.

CIRCUIT WIRING CABLES

Next we come to the cables necessary for general wiring on the vehicle.

These are all special cables for the work, and comprise a number of copper strands in rubber and fabric sheaths, specially treated to be highly resistant to petrol, water and oil. Such cables are freely available on the market as auto-cable.

There are *five* sizes of cable altogether in general use on the 12 volt system, but for most purposes *three* are commonly used. These are :—

1. The battery feed circuit cable, comprising 44 strands of .012 copper, generally described as 44/012. This cable has a current carrying capacity of approximately 22 amperes.
2. Main generator or head lamp circuit cables, comprising 28 strands of .012 copper (28/012) with a current carrying capacity of 14 amperes. For most purposes this is adequate.
3. Side and tail lamp wiring, accessory, ignition and generator field circuits comprising 14 strands of .012 copper (14/012) with a current carrying capacity of 7 amperes.
4. For panel lamp wiring and other incidentals a cable comprising 9 strands of .012 copper (9/012) is the most convenient size.

It should be realised that this is only a general guide to the cables used in the different circuits. New

2. Car wiring cables, of which there are four popular sizes and as many colours as can be conveniently stocked by the average motor trader.
3. Ignition cables which are subdivided into two types :
 - (a) High tension cable, i.e. for spark plugs, etc.
 - (b) Low tension cable, for primary, or low voltage circuits.

STARTER CABLES

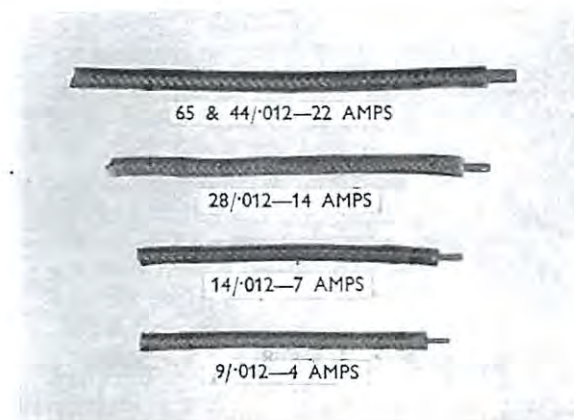

vehicles with Lucas wiring are carefully studied to determine the correct cable sizes. Where long lengths of cable are used, a larger gauge wire may be necessary to prevent excessive voltage drop.

For example, a vehicle with an exceptionally long cable run for the battery feed, six feet or more, may be installed with an oversize cable, such as 65/012. If at any time this cable has to be renewed, a similar size replacement should be installed. This last ruling also applies to re-wiring on vehicles equipped with the 6 volt system, particularly if voltage drop trouble is encountered.

EQUIVALENT CABLES — CURRENT CARRYING CAPACITY

It may be useful to examine how the cable sizes which have been given, compare with similar cables identified by other standards of measurement. Some cable manufacturers describe their cables in terms of standard wire gauge and this illustration shows the equivalent sizes which will carry the same amount of current.

For example :—Our 44/012 will compare with 44 strands of 30 SWG wire or 100 strands of No. 36 SWG, all having the same cross sectional area of copper which determines the amount of current which can be carried with a specified minimum voltage loss, i.e. voltage drop.

CAR TYPE CABLES

| | |
|------------------------|--------|
| 9/012 (30 SWG) EQUIV. | 23/36 |
| 14/012 (30 SWG) EQUIV. | 40/36 |
| 28/012 (30 SWG) EQUIV. | 70/36 |
| 44/012 (30 SWG) EQUIV. | 100/36 |



IGNITION CABLES

1. The 7 m/m high tension rubber cable is generally used for spark plugs and distributor or magneto leads.

There are numerous grades of this widely used cable at varying prices, but it is always good policy to buy high quality in order to obtain maximum durability in service. This avoids failures as a result of deterioration and cracking, which may cause elusive and annoying misfiring or, perhaps, complete breakdown.

The top three cables shown in the illustration are Lucas H.T. cables which all use Neoprene outer casings. This material has proved to be the best possible protection against heat, oil, petrol and water.

2. The 4 and 5 m/m low tension cables, which will carry up to about 7 amperes, are widely used for motor cycle work and are equally suitable for any exposed working conditions, where the cable is *not* subjected to oil or petrol.

We have mentioned altogether ten cables, commencing at the heavy type starter cable carrying up to 700 amperes, and finishing with the 4 and 5 m.m. mainly used on motor cycles. These ten different sized cables, together with earth braid, constitute the minimum range which should be stocked for general motor work.

Individual Wiring Circuits

THE WIRING CIRCUITS

Whilst a car wiring layout as a whole may appear complicated at first sight, the complete arrangement may be broken down into separate circuits as follows :—

1. Battery and Starter Circuits.

2. The Ignition Circuit.
3. The Charging Circuit.
4. Lighting Circuits.
5. Accessories Circuit.

CIRCUIT IDENTIFICATION — BATTERY, IGNITION AND CHARGING

To distinguish these circuits, a distinctive colour scheme is used.

The value of such a colour scheme on the car assembly line is obvious, and, once it is understood, it is of equal value in service fault finding. So before we discuss all the wiring circuits we must know about the colours employed.

Eight basic colours are used as follows, with an

appropriate coloured tracer.

1. Plain, *brown* cable or *brown with coloured tracer* in it, is used as the current supply or feed wire to all services.
2. *White* for the ignition circuit, and all component feeds which are essential when the ignition is switched on.
3. *Yellow* or *yellow with coloured tracer* is used for the generator and field circuit.

CIRCUIT IDENTIFICATION. LIGHTING AND ACCESSORIES

4. *Red* for the side and tail lamp circuits, starting from the lighting switch.
5. *Blue* for the headlamp lighting circuit, also starting from the lighting switch.
6. *Purple* is used for the auxiliary circuits which are fed from the ammeter and protected by a fuse A2.

7. *Green* is used for the auxiliary circuits which are fed through the ignition switch and protected by a fuse, A4.
8. *Black* is used for the earth circuit. That is, if a component is not fixed directly to the chassis, a cable must be taken to a good earthing point on the chassis, and this cable will always be *black*.

THE TYPICAL WIRING CIRCUIT

We can now deal with the wiring circuits as applied to modern vehicles.

Generally, the electrical system of a motor vehicle can be considered as a series of simple circuits, each consisting of the component (1), its switch, (2), and three wires, comprising the feed, switch wire and return (3), this return being provided by the frame of the vehicle, although, in the case of components insulated from the chassis, an earthing lead is also necessary.

Some variations are to be found, such as fuses, two-way switching and so on, but the principle of feed wire, switch wire and return remains, and it is upon this that the Lucas wiring colour scheme is based.

Feed wires carry braiding of a main colour only. Switch wires have the main colour of feed with a coloured tracer woven spirally into the braiding. The return or earthing leads are black.

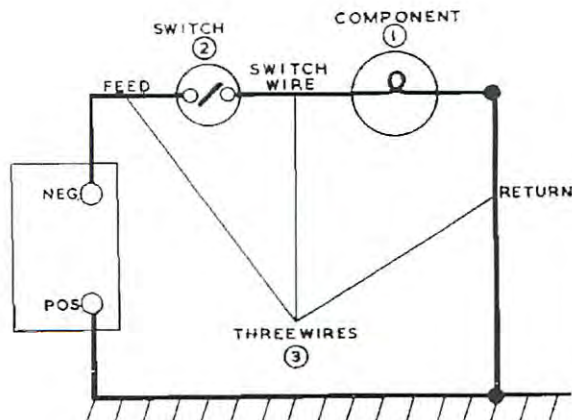

LUCAS ELECTRICAL EQUIPMENT

HOME AND EXPORT MODELS

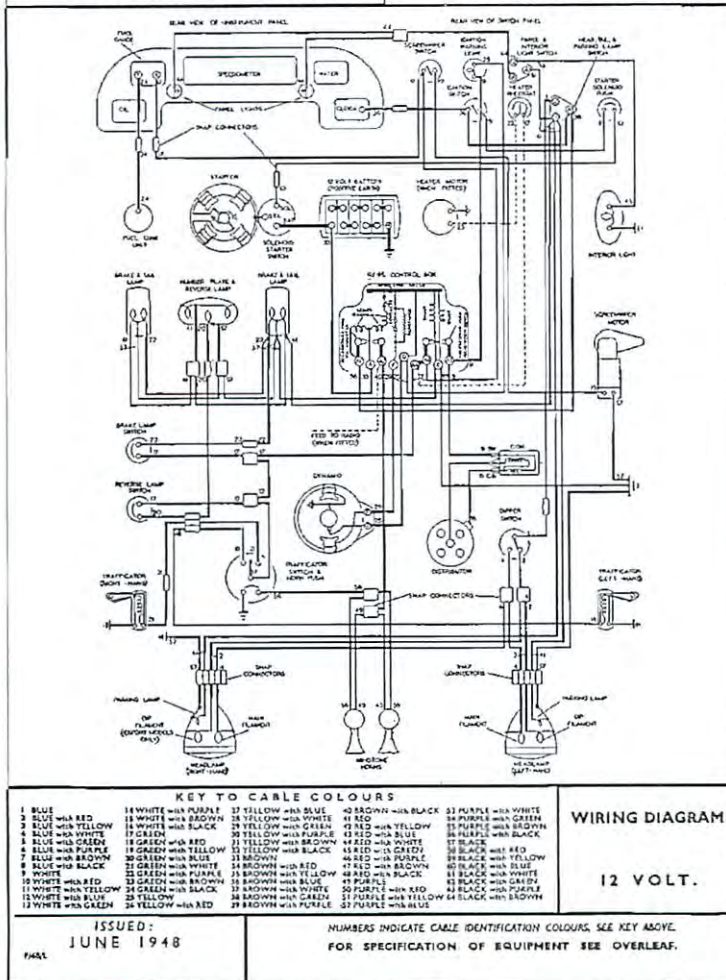

THE STANDARD WIRING DIAGRAM

Here we have a typical wiring diagram of which there is one published for most models and makes of vehicles. These diagrams are of considerable value in service, but a certain amount of difficulty may be experienced by the non-specialist in following them out.

It is however, quite simple if each component circuit is considered individually which we shall proceed to do, commencing with the starter system.

COMMON BATTERY SUPPLY CIRCUIT

The current supply for all circuits on the vehicle commences either direct from the battery negative terminal, or from the battery side of the starter switch.

It comprises a *heavy brown* cable, first running from the battery to the control box 'A' terminal, and through the load windings of the regulator to the terminal 'A1.' From here a *brown and blue* cable leads to the lighting switch where it loops off to one side of the ignition switch (terminal 'A').

If an ammeter is installed, it will be placed in the brown lead between the source of supply and the control box 'A' terminal, the cable becoming *brown and white* between the ammeter and the control box.

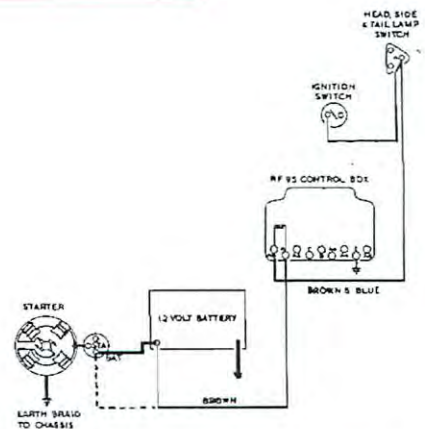

THE BATTERY SUPPLY CIRCUIT.

THE STARTER CIRCUIT — WITH MANUAL SWITCH

The first and most elementary circuit is that of the starter motor system. This motor can be either manually or solenoid operated.

Our picture shows the manually operated starter motor circuit. The current path is from the negative terminal on the battery to the starter switch (1), across the switch contacts to the insulated terminal on the starter motor (2), through the starter to the engine block, then via the bonding strip to the chassis (3), returning to the positive terminal of the battery via the battery earth cable (4).

The earth cables 3 and 4 are most important to the successful operation of the starter, particularly under cold starting conditions and must always be well maintained.

Where a solenoid starter switch is fitted, an additional relay circuit is introduced.

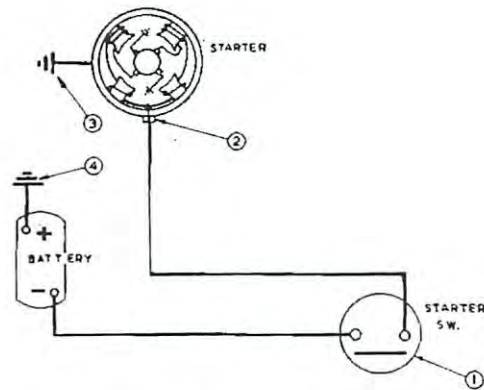

STANDARD STARTER WITH MANUALLY OPERATED SWITCH

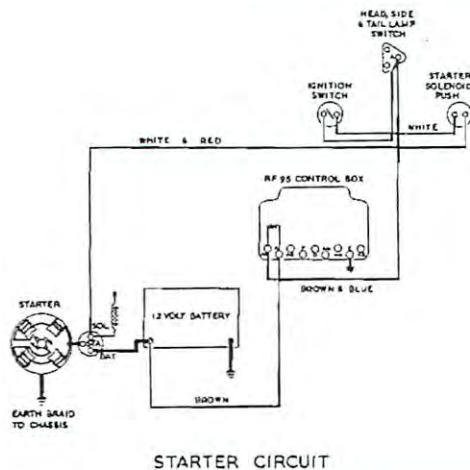

STARTER CIRCUIT

THE STARTER CIRCUIT-SOLENOID (RELAY) OPERATED

In this arrangement of the main starter circuit we have to add a solenoid operating circuit, and this is under the control of the ignition switch. That is, the starter solenoid can only be operated with the ignition switched on.

Firstly, there is the common supply from the battery to the ignition switch for all the circuits.

Our solenoid supply is taken from the other side of the ignition switch (A3) to the solenoid operating push by a white cable, and from this push to the solenoid winding by a *white and red* cable. The winding is earthed to the casing of the solenoid itself, thus completing the earth side of the circuit back to the battery earth.

THE IGNITION L.T. CIRCUIT

A white cable, commencing at the A3 terminal of the ignition switch is taken to the A3 terminal at the control box, and provides a common supply for the ignition units (coil and distributor) together with all the ignition accessories — fused and unfused — which are under the control of the ignition switch.

Using the A3 terminal on the control box as a junction point, a *white* (28/012) cable connects directly to the SW terminal of the ignition coil. A *white and black* cable joins the CB terminal of the ignition coil to the L.T. terminal of the distributor.

The unfused accessories such as the petrol pump and automatic choke will also be supplied from the A3 control box terminal using the *white* cable as the feed wire.

The ignition warning light feedwire, also a *white* cable is taken direct from the A3 terminal of the ignition switch.

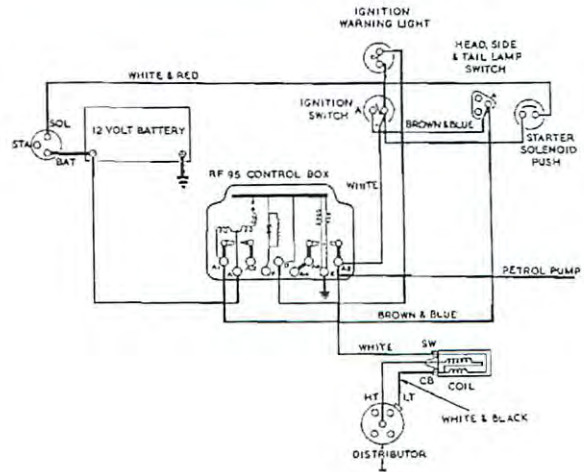

THE CHARGING CIRCUIT

The main components involved in the charging system are the generator, control box and battery.

That part of the circuit connecting the battery with the control box has already been dealt with as the *brown* battery supply circuit.

The generator circuit itself consists of a *yellow* (28/012) cable from generator 'D' terminal to control box 'D', and a *yellow green* (14/012) from generator 'F' terminal to control box 'F'.

Additionally, there is a *yellow* (14/012) cable connecting from control box 'D' to one side of the ignition warning lamp.

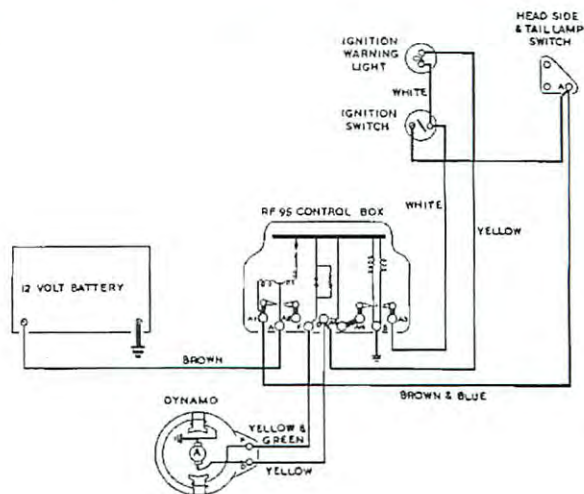

THE IGNITION WARNING LAMP

This indicator lamp performs two functions :-

1. It indicates that the battery current is switched on to the ignition and ignition-fed accessories.
2. It indicates that the generator is charging when the engine is turning at charging speed.

Follow the previous circuit through. Commencing at the A3 terminal of the ignition switch, an extension of the *white* lead is carried to one side of the warning light. From the other side, a *yellow* lead is taken direct to the 'D' terminal at the control box.

When the ignition switch is closed, current feeds

from terminal A3 at the switch, through the warning lamp to the 'D' terminal of the generator, the circuit being completed through the generator winding to earth. The lamp therefore lights up.

When the engine is started, and the generator voltage builds up to 12 volts, it opposes and equalises the battery voltage previously applied to the lamp, and no current will flow through it. The light goes out, and remains so, until the generator ceases to charge, and its voltage falls. Battery current will then pass through the lamp again and it will remain alight until the ignition switch is moved to the 'off' position.

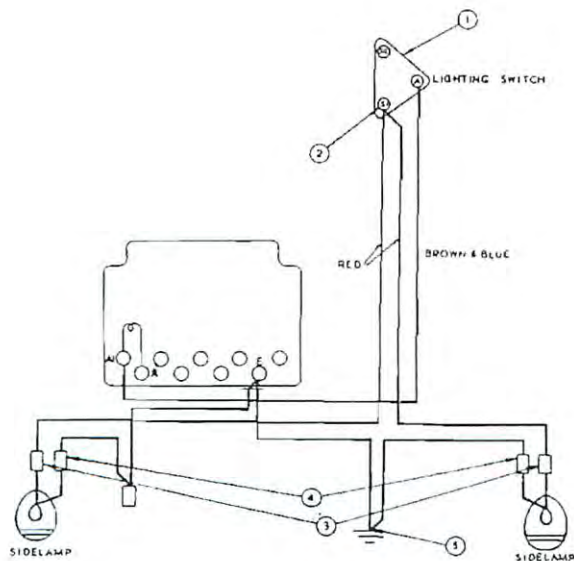

SIDELAMP CIRCUIT

SIDELAMP CIRCUIT

This picture features the sidelamp circuit.

Commencing at the lighting switch terminal S1(2), a separate *red* cable runs to each side lamp via a snap connector (3).

The return cable is *black* and you will notice that, in this case, it is a full return through snap connectors (4) to a special earthing terminal on the chassis (5).

This was evidently required on this particular model to assure a good return path, and it would be very necessary to check this if any trouble were experienced with the sidelamps.

REAR ILLUMINATION

In this example the rear illumination comprises tail lamp, one on each side, and also the number plate box lighting comprising two bulbs.

Commencing at the S1 terminal on the lighting switch (1) from which the side lamp feeds are also connected, another *red* cable runs directly to the first tail lamp (2). This red cable 'loops' out again to a snap connector located in the luggage boot (3). From this snap connector, two more red cables feed the second tail lamp (4) and the two bulbs wired in parallel in the number plate box (5).

You will notice particularly that a *black* earth wire connects from both tail lamps and the number plate box, to the earth terminal on the control box, and thence to the chassis earth (6).

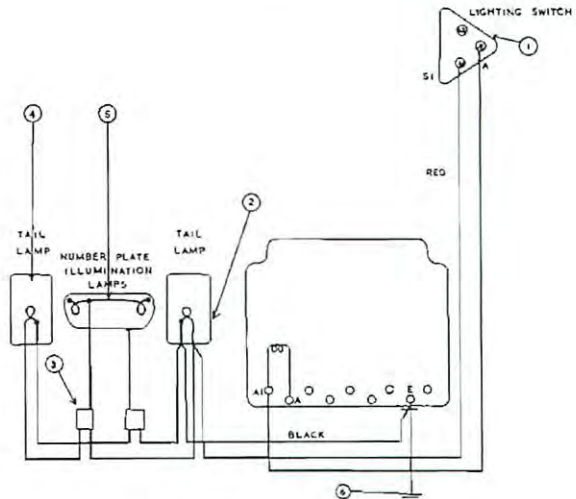

REAR LIGHTING CIRCUIT

THE HEAD LIGHT CIRCUIT

We have already explained that all the main lighting current passes over the load-turns on the voltage regulator to the lighting switch.

So we can commence at the S2 terminal on the lighting switch (1).

From this point, a *blue* cable runs via a snap connector (2) direct to the foot dipper switch (3).

The dipper switch is a two way switch. From one terminal two *blue* and *white* cables connect through snap connectors (4) to the *main* filament in each headlamp bulb (5).

From the other terminal on the two way switch, two *blue* and *red* cables run through snap connectors (6) to the dip filament in each headlamp bulb.

Here again, separate *black* earth cables are fitted to ensure a good return path for the lamps. These earth cables connect direct from the bulb holders in the lamp, via the control box earth terminal, to the common earth point on the chassis.

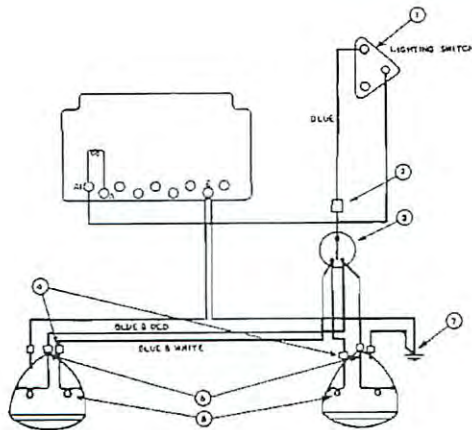

HEADLAMP CIRCUIT

THE INSTRUMENT PANEL LIGHTING

The last item is the lighting on the instrument panel. This is generally fed from the sidelamp terminal on the lighting switch.

On this model a *red* feed cable, commencing from the lighting switch (1), supplies the panel switch (2), and this loops as a *red and white* cable to a snap connector and the individual panel lights. In this case there is no separate earth cable.

From the panel switch (2), there is a *red and green* cable (3), which feeds the interior lamp (4), and also an earth cable (5), which is a *black* cable direct to the chassis.

Notice that the interior light is wired directly to the panel light switch, but, generally, interior lights are fused, taking their supply from the A2 fuse.

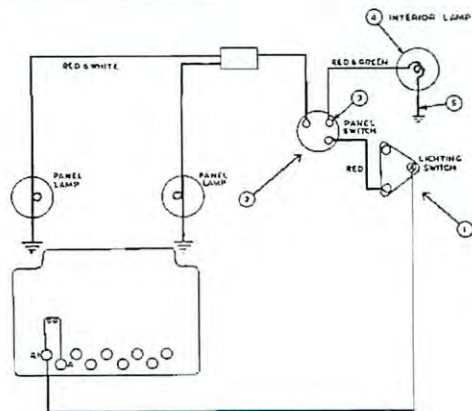

PANEL LAMP CIRCUIT

THE COMPLETE LIGHTING CIRCUIT

Here we have the wiring diagram of the complete lighting installation; we have seen just how simple this is by breaking it up into individual circuits.

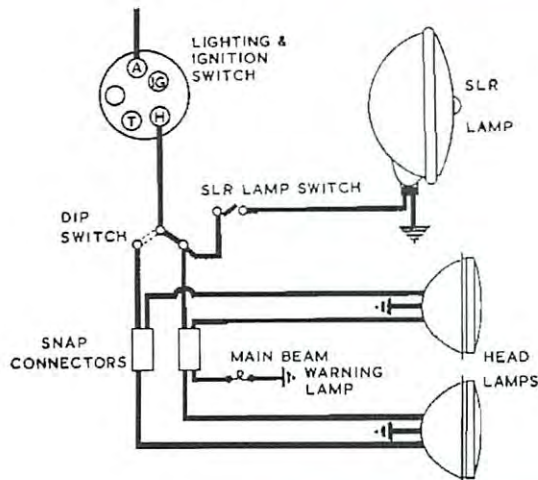
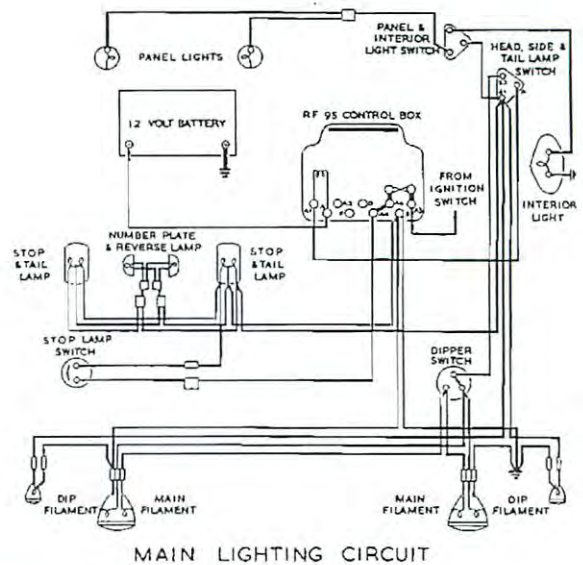

THE LONG RANGE DRIVING LAMP

The most satisfactory arrangement for installing this lamp is such that when the head lights are dipped the SLR lamp should automatically go out, thus avoiding the necessity for two separate operations.

This result can be conveniently obtained by taking a *red and blue* (28/012) cable direct from the main beam terminal of the dipper switch.

An additional hand control switch may then be inserted in this feed line to enable the driver to have the SLR on with his head lamps on main beam. With this arrangement the lamp will immediately go out when the head lights are dipped.

FOG AND PASS LAMPS

When fitted as initial equipment, fog and pass lamps will usually take their current supply from the 'S' or 'T' terminals on the lighting switch so that they may be automatically switched off with the side lamps. If such lamps are fitted subsequently, this is still the most suitable method.

It is usual to wire these lamps by means of a *red* (28/012) cable from the lighting switch to the lamp switch, and follow with a *red and yellow* (28/012) to the lamp itself, making quite sure that the lamp has a good earth. If there is any doubt about this, a separate *black* earth wire should be installed. The relatively large size of cable is necessary if full brilliance from the lamp is to be assured.

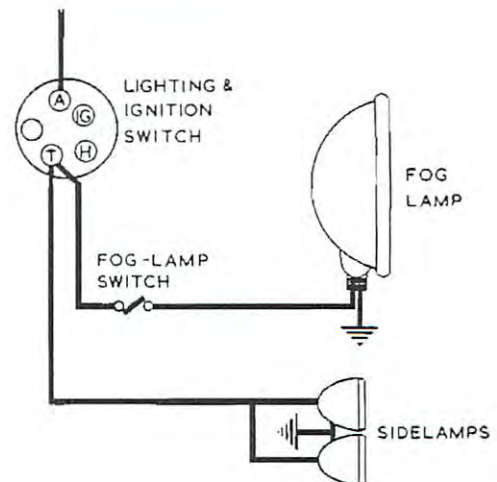

AUXILIARIES

There are three groups of auxiliaries and accessories, which take their current supply from either the 'A3', 'A4', or 'A2' terminals on the control box.

Those supplied from the 'A3' and 'A4' terminals are under the master control of the ignition switch. Since they are only required when the engine or vehicle is in motion, this practice precludes the possibility of their being accidentally left on, and so running the battery down.

The *unfused* components supplied from the A3 terminal will comprise the electric petrol pump, auto choke, petrol reserve solenoids etc.

The *fused* components supplied from the A4 terminal consist of trafficators, stop lamp, reverse lamp, windscreen wiper, fuel tank unit, demister and heater motors when fitted.

The A2 terminal and its fuse takes current direct from the battery through the *load* windings of the regulator and is used for interior lights, door lights, low current horns.

The heavy-current horns, such as the wind-tone models, and also radio sets will preferably have separate fuses, the initial supply being taken from the 'A' terminal of the control box, that is, directly from the battery and not through the load windings of the regulator.

There remain a few additional items, which, for special reasons, may take current direct from the battery. Two popular ones will be the cigar lighter, which takes a very heavy current and the inspection lamp sockets, which may be required when everything else is off.

We shall now examine all these auxiliary circuits individually commencing with the A4 fused auxiliaries under the control of the ignition switch.

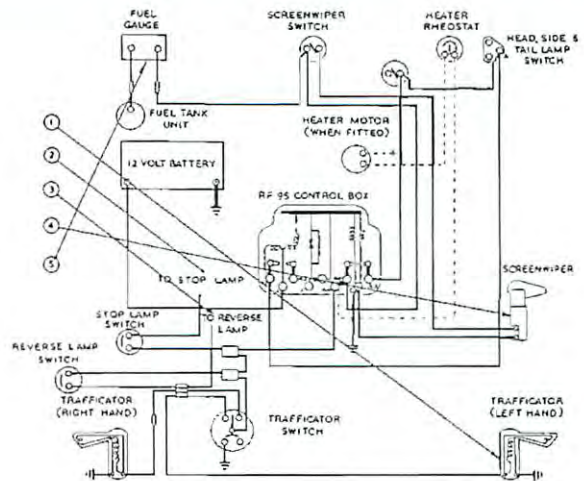

A 4 CIRCUIT

FUSED AUXILIARY CIRCUITS ON A4

Now let us examine these A4 circuits on an actual vehicle.

They are the most complicated of any, and we shall consider each one separately.

As this picture shows, there are only five altogether on this particular model, i.e.

1. Trafficators.
2. Stop Lamp.
3. Reverse Lamp.
4. Windscreen Wiper.
5. Fuel Tank Unit.

THE TRAFFICATOR CIRCUIT

Trafficators are supplied from the A4(1), 35 amp. fuse, local control being provided either by a self-cancelling two-way and off switch on the steering column, or alternatively by a similar type of switch on the panel.

The most usual 'run' of this circuit is as follows :

A *green* cable (14/012) from A4 on the control box feeds to a *twin spring connector* (2).

Two leads branch from this connector, one to the stop lamp switch, the other to a further spring connector (3) located at the bottom of the steering column. From here one lead branches off to the reverse lamp switch, the other to the trafficator and horn switch at the top of the steering column (4).

Two cables *green and white*, and *green and red*, lead from this switch and connect, each to one trafficator, through an additional spring connector (5) also located at the bottom of the steering column.

In the majority of cases, a separate *black* earth lead will be run from each trafficator to an earthing point, as shown at (6).

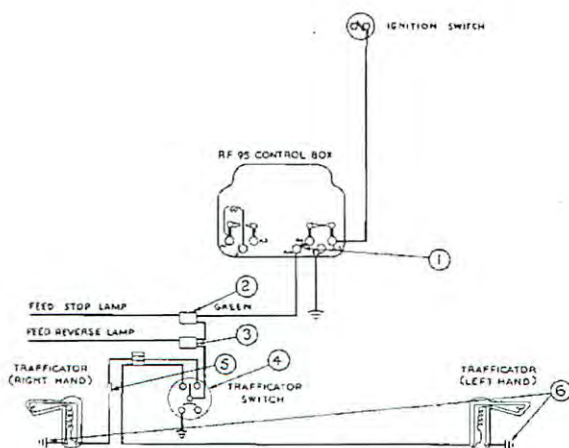

THE STOP AND REVERSE LAMP CIRCUITS

We can now examine the stop lamp and reverse lamp circuits together.

You remember the common *green* feed wire from A4 on the control box branched away, still continuing as a *green* cable from the first snap connector (1) for the stop lamp. This further *green* cable leads direct to the stop lamp switch (2), sometimes a small hydraulic switch, mounted on the master brake cylinder. From the switch, it proceeds, via a rubber-covered snap connector (3) direct to the stop lamp (4), and thence to earth (5).

In the case of the reversing lamp, the feed comes off the second snap connector (6) and proceeds still as a *green* cable to the reverse lamp switch (7) usually mounted on the side, or end of the gearbox, and actuated when the reverse gear is selected.

From the switch, the switch wire proceeds as *green and blue* via another snap connector (8) direct to the reverse lamp (9) and thence to earth (10) through the bulb.

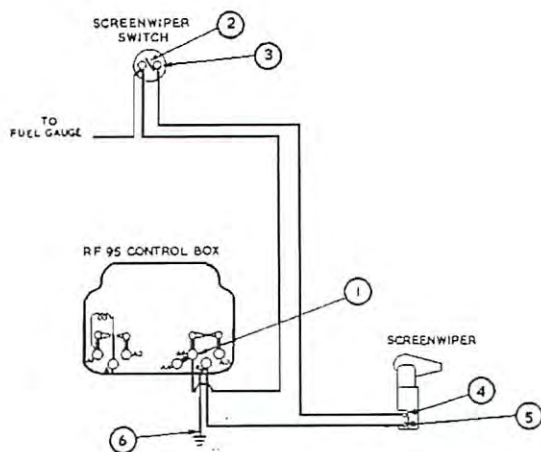
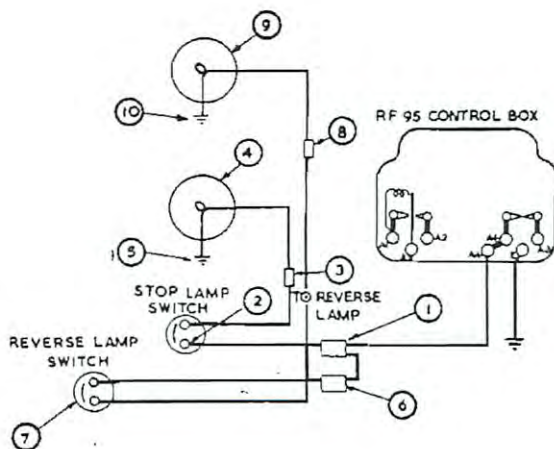

THE SCREENWIPER CIRCUIT

A second *green* feed wire from the A4 on control box (1) is used to supply the screen wiper and the petrol tank unit. This wire runs direct to one side of the screenwiper motor switch (2) which also acts as a junction point for the feed wire to the fuel tank unit. From the other side of the switch, the wire becomes *green and yellow* to one side of the screenwiper motor (4). From the other terminal on the motor (5) the cable is a *black* return to the 'E' terminal on the control box direct to a good earth on the chassis (6).

THE FUEL GAUGE AND PETROL TANK UNIT

As previously stated, the *green* feed wire for this component is junctioned off the screenwiper switch (1). From there it connects — still as a *green* cable — to the fuel gauge unit (2). From the gauge, the colour changes to *green and black* connecting through one or more snap connectors (3) to the petrol tank rheostat (4). The circuit is completed through this unit to earth.

In the event of any erratic reading on the gauge, the first thing to do would be to check the terminals for tightness, and open and remake the joints at the snap connectors, because either a loose or corroded connection will seriously affect the operation of the tank unit rheostat.

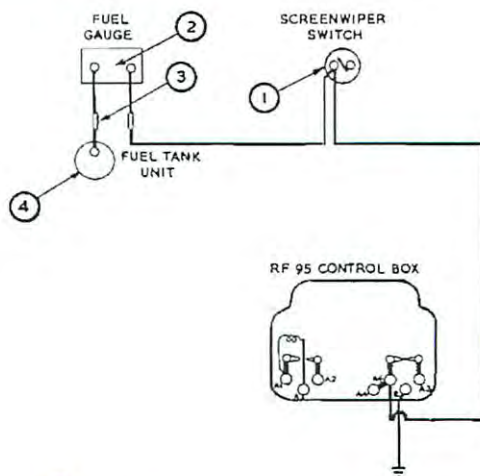

THE AUXILIARY CIRCUITS — A AND A2 ON CONTROL BOX

This picture shows a fairly typical layout for auxiliaries which are not under the master control of the ignition switch, and which may vary somewhat on different vehicles.

Top centre of the picture shows the inspection lamp sockets and a cigar lighter. It is usual to place these in the battery feed circuit before the ammeter. It would serve no useful purpose for the heavy current discharge from the cigar lighter to register on the ammeter; it would merely tend to alarm the driver. Similarly if the inspection lamp is dropped, and shorts as a result of bulb breakage, this would probably damage the ammeter. On the other hand a radio set for instance, which will have its own fuse, may be left on accidentally, or it may be in circuit for prolonged periods. It is therefore desirable that the discharge should be shown on the ammeter. Similarly, with heavy-current horns such as the windtones, to connect them through the ammeter would merely register as a violent and alarming oscillation of the needle when the horn button is closed, so a separate fuse is usually supplied with them, and the supply taken direct off the battery line.

Now examine this picture in detail. Such components as interior lights, door lights, etc., which may be susceptible to wiring troubles, will be placed on the 'A2' fuse cable colour *purple*. Small-current horns such as the Altette horn may also be connected to this fuse. The radio set with its own fuse, however, can most conveniently be connected from the 'A' terminal of the control box. The supply for the cigar

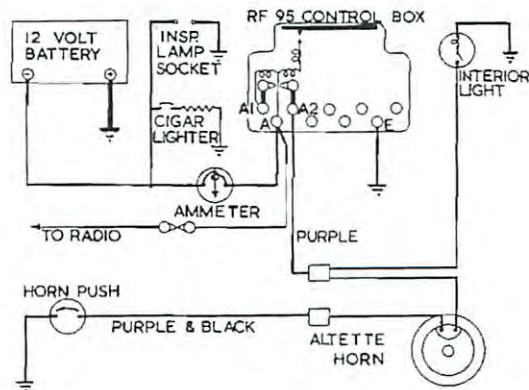

lighter and inspection plug sockets may be taken from the battery side of the starter switch as a matter of convenience. The supply for heavy duty horns may be taken from this point also, or, if no ammeter is installed, the windtone horn supply may be taken from the 'A' terminal at the control box. At least one car maker who does not install an ammeter takes the windtone horn supply from the 'A2' fuse, thus eliminating the additional horn fuse. Since there are no other components on this fuse, there is no possibility of putting the interior lights out of action because of a fault on the horn wiring. We have covered this item in some detail as a number of exceptions to the standard recommended layout may be found on different vehicles.

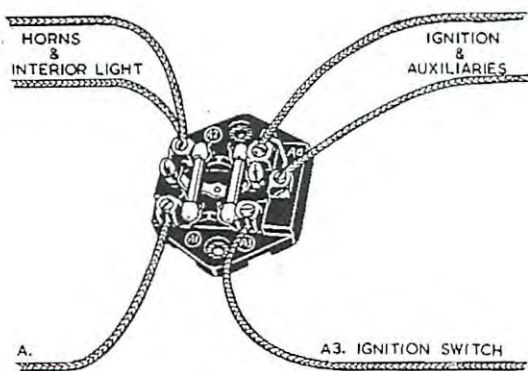

THE RB106 CONTROL UNIT AND FUSE BASE

Where the RB.106 control unit is installed, a separate fuse base is used.

There are two separate current supplies to this base:—

1. From the 'A' terminal on the control box a *brown* (44/012) cable connects to the terminal 'A1' on the base. The incidental accessories are connected at 'A2', that is, through the fuse.
2. The supply to the 'A3' terminal is taken from the ignition switch 'A3' by means of a *white* (28/012) cable. The ignition accessories, fused and unfused will be connected at 'A4' and 'A3' respectively.

GENERAL

Vehicle re-wiring work properly organized is capable of producing a useful revenue, as well as providing an essential service facility which no motor engineer can really afford to neglect.

The work as a whole falls into four different categories :—

1. Incidental wiring work such as may be involved in the fitting up of accessory lamps and other components.
2. Renewing single cables within the wiring harness or external to it.
3. The re-wiring of complete sections, following damage by collision, fire, etc.
4. Complete rewires involved in major vehicle overhauls.

In this latter category it is feasible to fit a completely new wiring harness, but owing to the multiplicity of models it is not practicable to make them available as spares; the delay involved in obtaining a special harness would be completely prohibitive.

In any of the categories mentioned, in order to carry out a good quality job on an economical and profitable basis, properly organised stocks of cables, sleeving, jointers, clips, etc. must be available and the range and quantities of these components will vary according to the amount of work anticipated.

If rewiring work is to be made a speciality, a wide range of stock controlled components will be required, otherwise the work will quickly become uneconomical as the result of delays and time lost in making-up special bits and pieces.

Within our experience, service complaints following re-wiring work can be all too frequent, and in this section of the course we shall attempt to offer some useful guidance to those undertaking it.

In every case, the fundamentals of a good quality, economical job may be assured if :—

1. The correct size and quality of cable is used.
2. Adequate stocks of the basic colours are maintained.
3. Suitable stocks of protective sleeving are available.
4. A full range of quick jointers, junction boxes and other incidentals are at hand.

Where the work is to be extensive, additional facilities in the way of guillotines, wire strippers, and other special tools for fitting up will go far in making the work more profitable.

Finally, although such work may have to be carried out by relatively inexperienced personnel, a good quick job can only be expected from an experienced electrician. At the same time, practice will soon result in increased speed and proficiency.

CABLE STOCKS SIZES AND COLOURS

The following cables constitute the minimum range necessary. Quantities can be adjusted to suit the conditions and volume of work, availability, etc.

The essentials extracted from our Catalogue No. 502F are as follows :—

Starter Cables :

1. 37/20 — for the 12 volt system.
2. 61/20 — for the 6 volt system.
3. 61/18 — for heavy C.V. work.
4. Earthing braids.

Circuit Wiring Cables :

5. 44/012 max. 22 amperes brown.
6. 28/012 max. 14 amperes yellow, blue, white,

purple and black.

7. 14/012 max. 7 amperes red, green, white and yellow.

When all the coloured cables are not obtainable, short lengths of coloured sleeving will aid identification.

Ignition Cables.

8. 7 m/m. H.T. Neoprene UM.827.
For motor cycle wiring } 5 m/m. Low Tension,
and miscellaneous pur- } rubber covered.
poses.

Multi-Core Cables :

An assortment of these is essential for steering column re-wiring and they are available with from two to seven cores according to requirements.

PROTECTIVE SLEEVING AND RUBBER GROMMETS

It is essential that all new wiring should be protected against chafing and exposure at vulnerable points.

For this purpose the most generally suitable material will be lengths of oil-proof plastic sleeving (PVC) which can be cut down to suit individual requirements.

The taping together of runs of cable is unsatisfactory in service, and is instantly recognisable as bad workmanship.

The following minimum range of six sizes will be required :

Sleeving :

- 5 m/m. dia. to carry one cable.
7 " " " " two cables.
11 " " " " three to four cables.
15 " " " " five to six cables.
18 " " " " seven to nine cables.
22 " " " " ten and over.

Rubber Grommets :

- $\frac{1}{4}$ " bore to fit $\frac{1}{2}$ " hole.
 $\frac{1}{2}$ " " " " $\frac{3}{4}$ " hole.
1" " " " 1 $\frac{1}{4}$ " hole.

JOINTERS — SNAP CONNECTORS AND JUNCTION BOXES

The comprehensive range of connectors and junction boxes illustrated in our Cable Catalogue No. 502F will cover all requirements.

CABLE CLIPS

A good range of cable eyelets or terminals, and also spring and screw fixing clips are other essentials to economical rewiring work, and a comprehensive range is illustrated in our catalogue No. 502F. Typical samples are as follows :—

1. Junction Boxes : These are available with 2, 4, 6 and 8 terminal positions.
2. Cable Clips : The essentials here are single and

The only alternative to these connectors is twisted and soldered joints, a slow business.

In no circumstances should dry joints be permitted. These deteriorate badly in service and are visible evidence of bad workmanship.

double cable clips.

3. Cable Harness Clips and Spring Clips for chassis fixing.
4. Cable Eyelets, or Terminals. $\frac{3}{16}$ ", $\frac{1}{4}$ ", $\frac{5}{16}$ " and $\frac{3}{8}$ " eyelets will cover all requirements.
5. Starter Cable Terminals.
6. Battery Lugs and Earth Straps.

This is the simplest form of wiring work :

WIRING UP ACCESSORY LAMPS OR RENEWING SINGLE CABLES

1. Always use the recommended size of cable and the correct basic colour, which makes for easy identification subsequently, and also enhances the appearance of the job.
2. Take great care to ' feed ' the component from the correct fuse or terminal point, as we have already detailed.
3. Protect the new wire with sleeving where necessary.
4. Clip up sufficiently close to prevent sagging in

service which would give a consequent untidy appearance.

5. Avoid close proximity to any ' Hot Spots ' and any moving parts such as brake cables, etc.

It happens that sometimes a single cable in the harness may require renewal, and the obvious way to do this is to run a new cable of the correct size, and major colour, outside the loom. This may be clipped on to the loom at intervals. Finally cut off the old cable ends where they enter the harness.

PARTIAL REWIRES

A typical service rewiring job will be where a section of wiring has become damaged due to a smash or a fire.

In this circumstance the best and quite adequate method is to cut away all the damaged wiring, if possible at a common point. Then, using either a

multi-point terminal block, a junction box or a few snap connectors, run new cables of the correct size and basic colour to the various components. In many cases it will be possible to re-use the old cable run, including the rubber grommets, clips, etc.; otherwise, fit new pieces of insulating sleeving, rubber grommets and cable clips as required.

COMPLETE REWIRES

In view of the large amount of labour involved in the re-wiring of any modern vehicle, this job merits careful consideration and a strictly methodical approach.

Job instructions may only specify a re-wire, but it is obviously futile to re-wire a vehicle to find afterwards that when the vehicle is put back into service the generator doesn't charge or the battery is flat and so on.

So, the very first thing to do is to make a general check-over of all the units, including the lamps and ascertain that they are in a serviceable condition. Proceed as follows :—

Whilst in contact with the customer make a visual check of the following :

1. The battery.

2. The distributor, leads, and ignition coil.
3. The generator, belt, commutator, brushes, bearings.
4. The control box condition.
5. The starter commutator, brushes and bearings. Listen to the engagement for undue noise.
6. The lighting — check the condition and operation where possible. Note cracked glasses, ill-fitting rims, etc.
7. The accessories : This general check-over will take about a quarter of an hour.

Remove any units which may require attention in the way of overhaul or minor repairs.

The main job of re-wiring the vehicle can then be tackled.

METHODS OF REWIRING

Where only inexperienced labour is available, the best method is to disconnect the leads from their components, and then remove the complete harness intact if possible.

During the removal of the main harness, some decision will have to be made as to whether such additional cables as trafficator leads, interior lights, etc., which are in the overhaul, require renewing. Generally this will not be necessary. On the other hand the leads passing into the steering column assembly will almost invariably need replacing. Some care should be taken over this, as such rewiring necessitates the use of the correct multi-core cable.

Lay the harness carefully on a suitable size bench and position it with a few stout nails to act as locating pins.

A complete new set of cables can now be run, using the old loom as a pattern. Tie the cables together at junctions and apply sleeving where required.

Finally, re-assemble the complete new harness on to the vehicle and re-connect to the components.

The more experienced man, who fully understands his circuits, and is thoroughly familiar with the work,

will prefer to chop the old harness out piecemeal and run his new wiring direct in situ.

Whichever method may be employed, a thorough and final check is necessary when the rewire is completed in order that a clean and effective job is assured.

This final check should comprise the following operations :

1. Replace the charged battery on the vehicle, making sure that earth connections are clean and tight — leave the main battery lead off.
2. Check that oil pipes, speedometer drive, etc., are properly connected.
3. Check that ALL switches are in the 'OFF' position, and that no odd leads are left disconnected.
4. Connect the main battery lug but do not tighten — this facilitates emergency removal.
5. Switch on ignition and start engine.
6. Check the charging.
7. Check all lights in turn.
8. Check all accessories in turn.
9. If everything is in order tighten the main battery lug.

SUMMARISING

Whilst it is not possible to cover every variation in circuit arrangements that a particular vehicle manufacturer may adopt, the various circuits which have been provided in this book represent the standard layout employed for most vehicles. If these are properly understood, very little difficulty will be experienced when confronted with the wiring arrangement on occasional special models, or even on new model cars now being produced. Such arrangements will vary only in detail from the general pattern.

In the same way, satisfactory re-wiring operations cannot be covered in any great detail. Various methods may be employed which are equally satisfactory; always providing that adequate stocks of cables and components are at hand.